

TRUSTED  
**SINCE 1958**  
WORLDWIDE

Precise.

Quality.

Reliable.



Taylor Valve Technology Multi-Orifice Valve Design Principle Provides Precision Control. The two adjacent internal discs each contain two precision orifices.

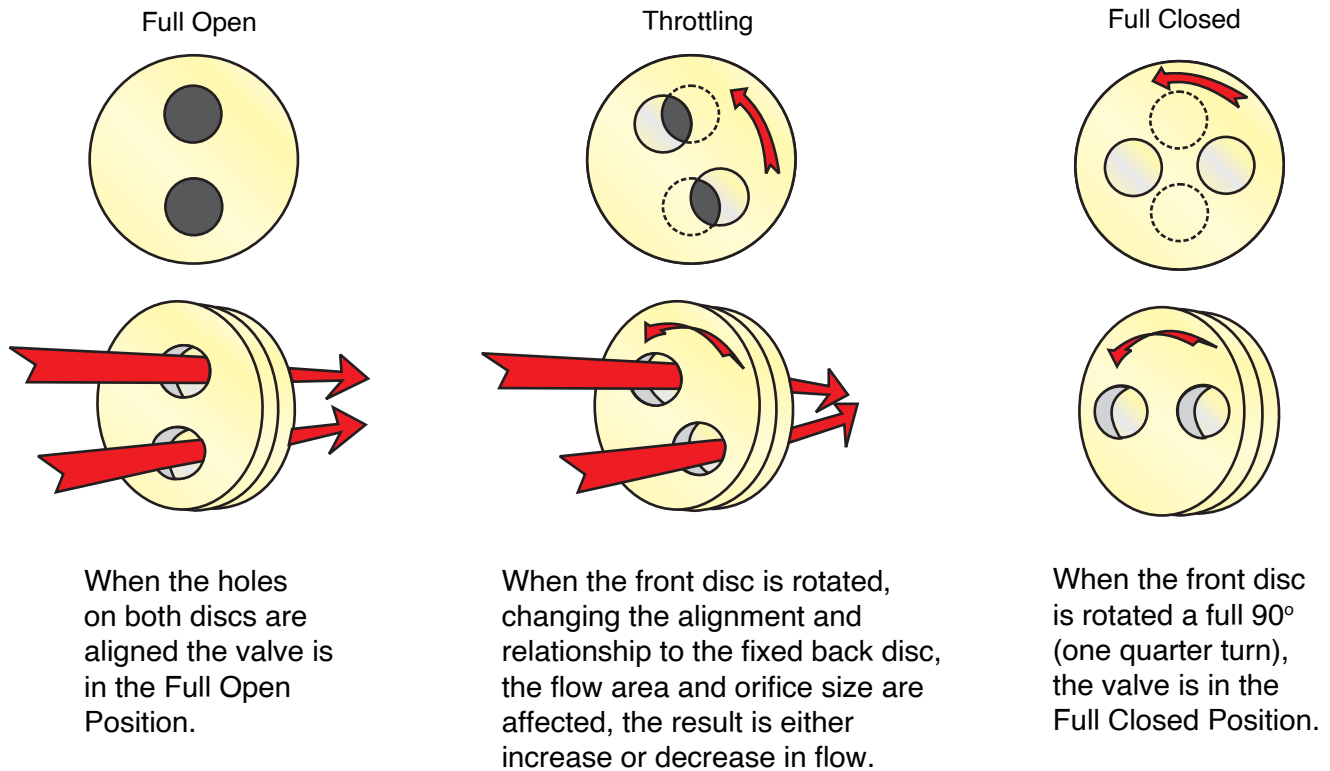

The discs are lapped to within two light bands of flatness (+/- .00002") to achieve positive shut off and maintain precise control. The fixed back disc is held perpendicular to the flow. The front disc floats against the back disc and seeks a mating surface promoting a positive seal. The differential pressure across the upstream disc and the downstream disc stabilizes the control surfaces. Vibration, noise or fatigues normally associated with loose or unsupported parts are eliminated. No control surfaces are introduced into the orifice, providing a clear center line for the flow. The valves are rated for shut-off at ANSI Class III or IV depending on the style of valve and trim used. The orifices of the standard disc expose a small control surface profile to the fluid steam reducing wear. The multi-orifice design produces near linear flow characteristics. The low torque and quarter-turn design of Taylor Valve Technology's Multi-orifice valves allows for a variety of actuation options: manual, pneumatic, hydraulic, or electric.

1" BODY STANDARD DIMENSIONS AND WEIGHTS				
CONNECTIONS		DIM. END-to-END IN. (MM.) +/- .10	WEIGHT	
INLET	OUTLET		LB.	KG.
1" FNPT	1" FNPT	8.92	22	9.99
1" BUTT WELD	1" BUTT WELD	8.92	22	9.99
1" 150 RFF	1" 150 RFF	13.48	28	12.71
1" 150 RTJ	1" 150 RTJ	13.85	28	12.71
1" 300 RFF	1" 300 RFF	13.98	30	13.62
1" 300 RTJ	1" 300 RTJ	14.35	30	13.62
1" 600 RFF	1" 600 RFF	14.48	30	13.62
1" 600 RTJ	1" 600 RTJ	14.48	30	13.62
1" 900 RFF	1" 900 RFF	15.35	40	18.16
1" 900 RTJ	1" 900 RTJ	15.35	40	18.16
1" 1500 RFF	1" 1500 RFF	15.35	40	18.16
1" 1500 RTJ	1" 1500 RTJ	15.35	40	18.16

### MC Inline Choke

1" & 2" Configuration

316 SS

¼ Turn Actuated

Body Rating = 3,600 PSI

CV Range = 0.70 - 16.57

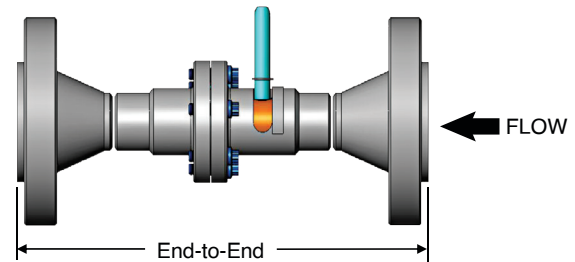

2" BODY STANDARD DIMENSIONS AND WEIGHTS				
CONNECTIONS		DIM. END-to-END IN. (MM.) +/- .10	WEIGHT	
INLET	OUTLET		LB.	KG.
2" FNPT	2" FNPT	10.04	23	10.40
2" BUTT WELD	2" BUTT WELD	9.80	22	9.99
2" 150 RFF	2" 150 RFF	14.98	34	15.44
2" 150 RTJ	2" 150 RTJ	15.35	34	15.44
2" 300 RFF	2" 300 RFF	15.48	40	18.16
2" 300 RTJ	2" 300 RTJ	15.98	40	18.16
2" 600 RFF	2" 600 RFF	16.23	46	20.88
2" 600 RTJ	2" 600 RTJ	16.36	46	20.88
2" 900 RFF	2" 900 RFF	18.48	72	32.69
2" 900 RTJ	2" 900 RTJ	18.61	72	32.69
2" 1500 RFF	2" 1500 RFF	18.48	72	32.69
2" 1500 RTJ	2" 1500 RTJ	18.61	72	32.69

No.	Description	Qty
1	Hub	1
2	O Ring	1
3	O Ring	1
4	Disc	2
5	O Ring	2
6	Backup Ring	2
7	Rotator	1
8	Cap Screw	6
9	Handle	1
10	Retaining Ring	1
11	Body	1
12*	Flow Tube	1
13**	Dowel Pins	5
14**	Drive Screw	2
15**	Index Label	1
16**	Data Plate	1
17**	Screw	2

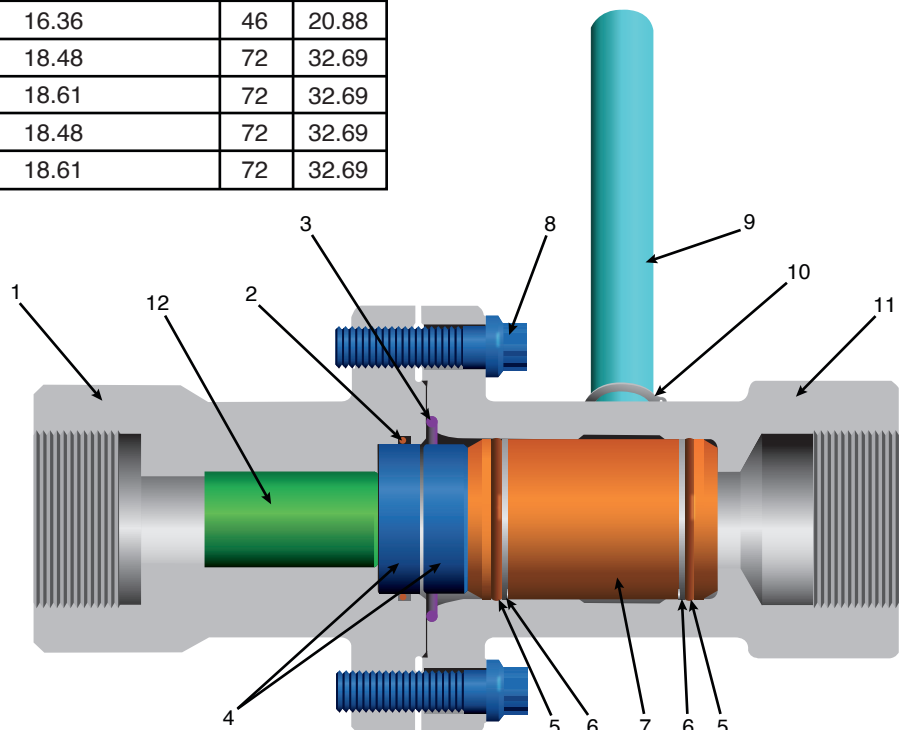

The information contained in these drawings is the sole property of Taylor Valve Technology Inc. and any reproduction in part or whole without the written permission of Taylor Valve Technology Inc. is prohibited.

NOTE: Taylor Valve reserves the right to change product designs and specifications without notice.

\*Item optional

\*\* Items not shown in section view



# MC SERIES CHOKE VALVES

## FEATURES & *Benefits*

- **Accurate Control** - 90 degree rotation from Full Off to Full On
- **Bolted Body** - Body is constructed with two bolted segments, avoiding the risk of corrosion, cross threading, galling of threaded type valve assemblies.
- **Extended Mean Time Between Service** - Robust design and liberal application of hardened materials, efficient flow-geometry means the valves offer maximum production potential and minimum service requirements.
- **Easy Maintenance** - Choke valves are designed to provide simple straightforward disassembly with no special tooling or fixtures.
- **Optional Features** - Choke valves can have trims and actuators custom designed for specific requirements, such as, special trims for noise reduction and sand control, several trims are available to accommodate high pressure flows or minimum pressure loss applications.



### Applications:

- Well Site Automation
- Water Injection Control Valve
- CO2 Injection Control Valve
- Pump Bypass
- Pump Startup
- Gas Lift Injection Control
- Blow Down and Dump Valve
- Steam Injection
- Throttling Valve
- High DP Valve
- Motor Operated Valve





**The MC Series of Inline MOV Chokes Offer:**

- ~ ANSI Class III Shut Off
- ~ Linear flow characteristics
- ~ Downstream Wear Resistant Flow Tube
- ~ Simple Design for easy field maintenance
- ~ Choice of materials for body standard is 316 SS
- ~ Threaded, Flanged, Butt Weld, and Victaulic End
- ~ Sizes from 1" and 2" Threaded to 3" Flanged

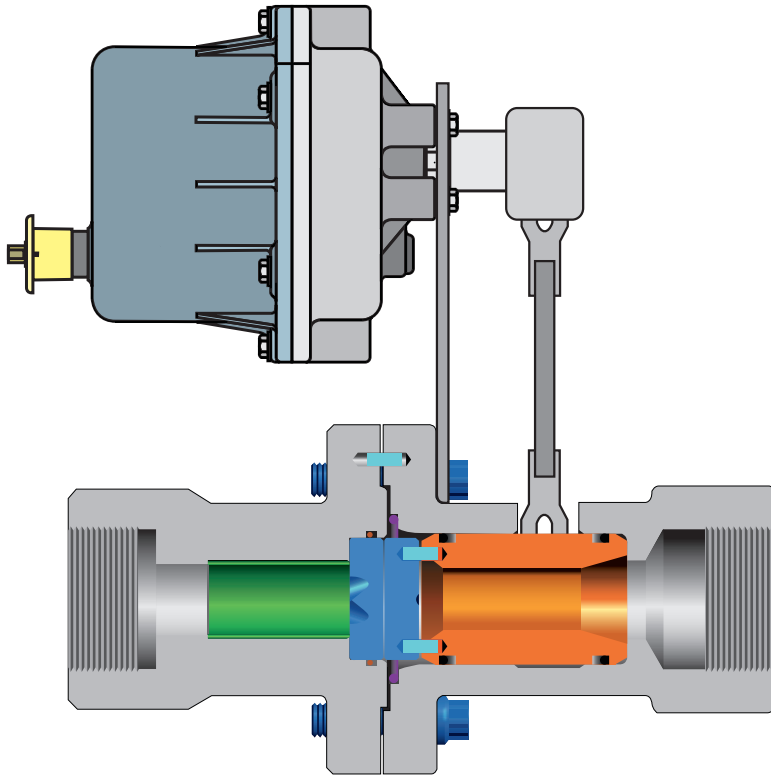

**Control Element Disc**

Ceramic disc recommended  
up to 1500 PSI Pressure Drops  
Tungsten Carbide above  
500 psi up to maximum  
operating pressure of valve.

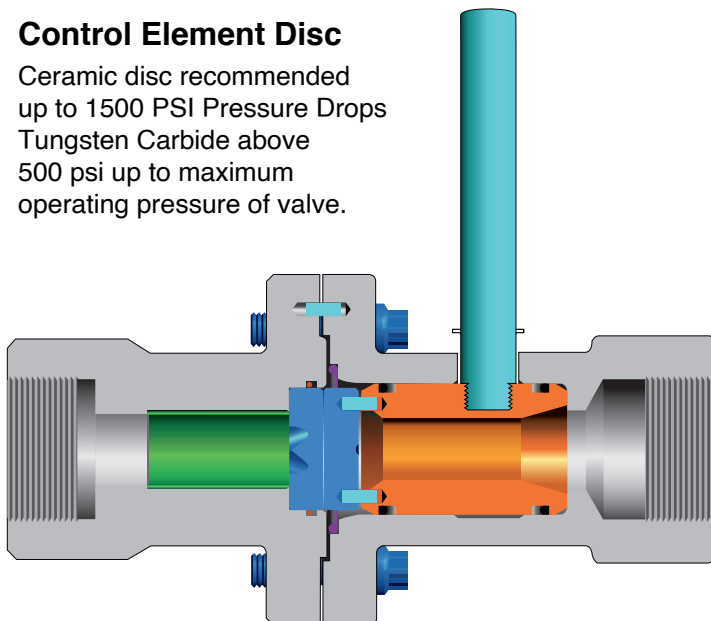

# NOMOGRAPHS

For  
WATER

**PRESSURE DROP (DP)  
ACROSS CHOKE (PSI)**

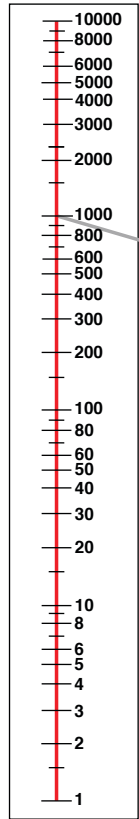

**FLOW RATE  
BBL/DAY GAL/MIN**

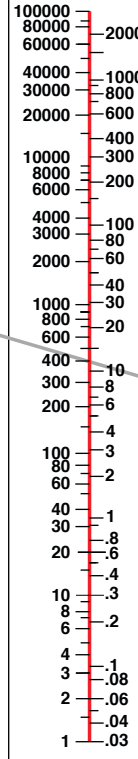

**ORIFICE SIZE  
Bean Size = 1/64th Dia**

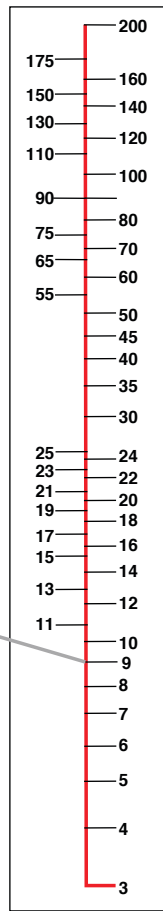

EXAMPLE:  
PRESSURE DROP DP 1000 PSI,  
WATER FLOW RATE 400 BARRELS  
PER DAY OR 2310 B/D DOUBLE  
ORIFICE CHOKE READ BEAN SIZE 9

NOTE: P1-P2 = DP  
WHEN P1 = UPSTREAM PRESSURE  
P2 = DOWNSTREAM PRESSURE  
DP = PRESSURE DROP ACROSS THE CHOKE

For  
GAS

**PRESSURE DROP (DP)  
ACROSS CHOKE (PSI)**

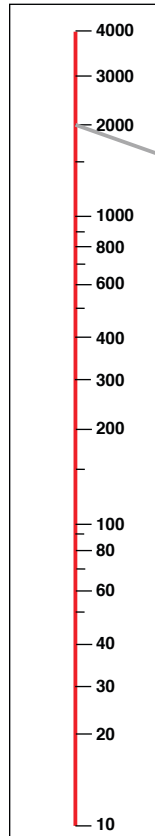

**FLOW RATE  
BBL/DAY GAL/MIN**

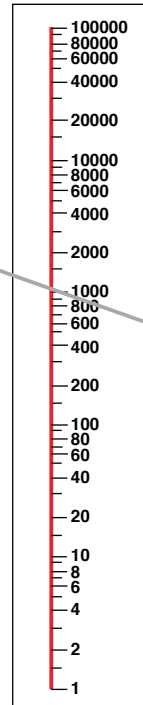

**ORIFICE SIZE  
Bean Size = 1/64th Dia**

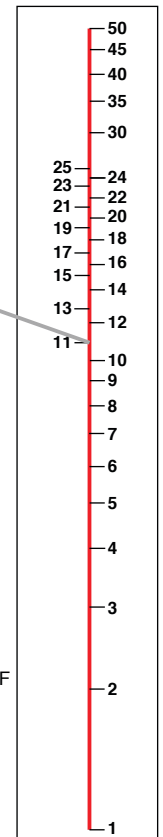

\* GAS FLOW AT .825 SPECIFIC GRAVITY AND TEMPERATURE AT 60 F  
\*\* STEAM QUALITY = 80%  
NOTE: LBS/HR of STEAM = LB/D \* 14.5

EXAMPLE:  
UPSTREAM PRESSURE IS 2000 PSI AND THE SETTING IS 11,  
GAS FLOW RATE WILL BE 1000 SCFD

# Sizing Information Flow Equations

## Liquid

Solve for  $C_v$

$$C_v = Q/34.3 \sqrt{\frac{\Delta P}{S_G}}$$

Solve for Flow (Q)

$$Q = 34.3 \times C_v \sqrt{\frac{\Delta P}{S_G}}$$

### Sizing Data for Liquids

- $P_1$  - Inlet Pressure (psia, psig, Bara, kPaa)
- $P_2$  - Outlet Pressure (psia, psig, Bara, kPaa)
- $Q_L$  - Flow (bbl/d, gal/min, lbs/hr, kg/hr, m/d)
- $S_G$  - Specific Gravity of Liquid
- T - Temperature ( F°, C°, R°, K°)

Where:

- $P_1$  = Inlet Pressure (psia)
- $P_2$  = Outlet Pressure (psia)
- $\Delta P = P_1 - P_2$
- Q = Flow Rate (BPD)
- $S_G$  = Specific Gravity - Water = 1.00
- $C_v$  = Valve coefficient of Flow

### 2 Phase Flow

- $P_1$  - Inlet Pressure (psia, psig, Bara, kPaa)
- $P_2$  - Outlet Pressure (psia, psig, Bara, kPaa)
- $Q_G$  - Flow (scf/d, m³/hr, kg/hr)
- $Q_L$  - Flow (bbl/d, gal/min, lbs/hr, kg/hr, m/d)
- $G_G$  - Specific Gravity of Gas
- $S_G$  - Specific Gravity of Liquid
- T - Temperature ( F°, C°, R°, K°)

## Gas

Solve for  $C_v$

$$C_v = Q / .0234 \sqrt{\frac{\Delta P (P_1 + P_2)}{G_G}}$$

Solve for Flow (Q)

$$Q = C_v \times .0234 \sqrt{\frac{\Delta P (P_1 + P_2)}{G_G}}$$

### Sizing Data for Gas Service

- $P_1$  - Inlet Pressure (psia, psig, Bara, kPaa)
- $P_2$  - Outlet Pressure (psia, psig, Bara, kPaa)
- $Q_G$  - Flow (scf/d, m³/hr, kg/hr)
- $G_G$  - Specific Gravity
- T - Temperature ( F°, C°, R°, K°)

Where:

- $P_1$  = Inlet Pressure (psia)
- $P_2$  = Outlet Pressure (psia)
- $\Delta P = P_1 - P_2$
- Q = Flow Rate (MMSCFD)
- $G_G$  = Specific Gravity - Air = 1.00
- $C_v$  = Valve coefficient of Flow

### Co2 (Gaseous)

- $P_1$  - Inlet Pressure (psia, psig, Bara, kPaa)
- $P_2$  - Outlet Pressure (psia, psig, Bara, kPaa)
- $Q_G$  - Flow (scf/d, m³/hr, kg/hr)
- $P_v$  - Vapor Pressure (Function of Temperature)
- V - Specific Volume (Function of Temperature and  $P_1$  Pressure)
- $SG_G$  - Specific Gravity of Gas
- T - Temperature ( F°, C°, R°, K°)



# Choke Nomenclature

Choke Series
CA
CI
MC
MCX
MDA
MDAS
MDI
MDIS
RB
RBHU (Hammer Union)

Size
1 1"
2 2"
3 3"
4 4"
6 6"

Service Type
0 Standard
1 NACE
2 Steam/High Temp.

Style
0 Non-flanged
1 RFF
2 RTJ
3 RFF X RTJ
4 RTJ X RFF
5 NPT X API

Trim Material
03 CARBIDE DISC - STELLITE WR SLV
04 CERAMIC DISC - STELLITE WR SLV
05 CARBIDE DISC - CARBIDE WR SLV
15 CERAMIC DISC - NO WR SLV
16 CARBIDE DISC - NO WR SLV
32 CERAMIC DISC/CARBIDE FLOW TUBE
44 R/RB-SERIES
47 BEAN 17-4 SS
17 CARBIDE DISCS & DIFFUSER
18 CERAMIC DISCS & DIFFUSER

Actuation Type
0 Manual Handle
1 Manual Gear
2 Electric
3 Pneumatic
4 Hydraulic
7 Positive Bean

Schedule
0 Non-flanged
1 40
2 80
3 160
4 XS
5 XXS
6 SLIP-ON
7 API
8 120
9 XXH X S80
A S80 X S40
B NPT X API
C S120 X S80

Body Material
00 DUPLEX SS
03 CARBON STEEL
04 LOW ALLOY (4130 LACS)
05 316 SS (CF8M)
06 316 SS "L" (CF3M)
07 ALUMINUM BRONZE
08 A350 LF2
09 LCC
10 INCONEL
11 SUPER DUPLEX SS
12 440 SS
13 410 SS

**EXAMPLE ONLY\*** MC - 2 0 0 17 17 1 2 04 05 03 04 = MC-20017171204050304  
Choke part number has to be 17 digits.

Inlet Connection		Outlet Connection	
01 1" FNPT	41	6" 600	
02 1" BUTT WELD	42	6" 900	
03 1" SOCKET WELD	43	6" 1500	
04 1" VICTAULIC	44	6" 2500	
05 1" 150	45	8" 150	
06 1" 300	46	8" 300	
07 1" 600	47	8" 600	
08 1" 900/1500	48	8" 900	
09 1" 2500	49	8" 1500	
10 2" FNPT	50	8" 2500	
12 2" BUTT WELD	51	2-1/16" 3000	
13 2" SOCKET WELD	52	2-1/16" 5000	
14 2" VICTAULIC	53	2-1/16" 10000	
15 2" 150	54	2-9/16" 3000	
16 2" 300	55	2-9/16" 5000	
17 2" 600	56	2-9/16" 10000	
18 2" 900/1500	57	3-1/8" 3000	
19 2" 2500	58	3-1/8" 5000	
20 3" FNPT	59	3-1/8" 10000	
21 3" BUTT WELD	60	4-1/16" 3000	
22 3" SOCKET WELD	61	4-1/16" 5000	
23 3" 150	62	1-13/16" 10000	
24 3" 300	63	3-1/16" 5000	
25 3" 600	64	3/4" 600#	
26 3" 900	65	1.5" 900/1500	
27 3" 1500	66	3-1/16" 10000	
28 3" 2500	67	7-1/16" 5000	
29 4" FNPT	68	1-13/16" 15000	
30 4" BUTT WELD	69	2-1/16" 15000	
31 4" SOCKET WELD	75	1" UNION	
32 4" VICTAULIC	76	3" 602M x 3" 602F Union	
33 4" 150	78	3-1/16" 15000	
34 4" 300	80	10" 600	
35 4" 600	81	10" 900	
36 4" 900	82	10" 1500	
37 4" 1500	83	10" 2500	
38 4" 2500	84	2-9/16" 15000	
39 6" 150	85	6" Butt Weld	
40 6" 300	87	1.5" 1500	

Orifice Size			
01 (2) 1/8" RND PORTS	29	48/64 BEAN	
02 (2) 3/16" RND PORTS	34	32/64 BEAN	
03 (2) 1/4" RND PORTS	43	40/64 BEAN	
04 (2) 3/8" RND PORTS	44	34/64 BEAN	
05 (2) 1/2" RND PORTS	45	28/64 BEAN	
06 (2) 5/8" PIE PORTS	46	30/64 BEAN	
07 (2) 3/4" RND PORTS	53	10/64 BEAN	
08 (2) 7/8" RND PORTS	63	11/64 BEAN	
10 (2) 1-3/16" RND PORTS	64	14/64 BEAN	
11 (2) 1-1/4" RND PORTS	65	15/64 BEAN	
14 (2) 1-1/2" RND PORTS	66	16/64 BEAN	
30 (2) 3/4" PIE PORTS	67	19/64 BEAN	
32 (2) 1-3/4" RND PORTS	68	20/64 BEAN	
35 (2) 1" ROUND PORTS	69	24/64 BEAN	
38 (2) 2" PIE PORTS	70	21/64 BEAN	
40 (2) 1-1/4" PIE PORTS	71	22/64 BEAN	
41 (2) 1-3/8" PIE PORTS	72	23/64 BEAN	
42 (2) 1-1/8" RND PORTS	73	27/64 BEAN	
47 (2) 1-1/2" PIE PORTS	74	29/64 BEAN	
49 (2) 5/8" RND PORTS	75	25/64 BEAN	
54 (2) 2.92 PIE HOLES	76	1/7" RND PORTS	
55 3 CV	77	7/64 BEAN	
56 12 CV	78	54/64 BEAN	
57 164 CV	79	44/64 BEAN	
58 420 CV	80	45/64 BEAN	
59 64 CV	81	47/64 BEAN	
60 35 CV	82	51/64 BEAN	
22 17/64 BEAN	83	35/64 BEAN	
23 18/64 BEAN	84	37/64 BEAN	
24 8/64 BEAN	85	6 CV	
25 13/64 BEAN	86	85 CV	
26 4/64 BEAN	87	12/64 BEAN	
27 38/64 BEAN	88	78 CV	
28 36/64 BEAN	89	42/64 BEAN	
	90	43/64 BEAN	
	91	41/64 BEAN	

Seal Material	
00 HNBR/HSN	
01 NBR	
03 EPDM	
04 FKM (VITON)	
05 NEOPRENE	
06 NBR (PEROXIDE CURED)	
07 STEAM SEALS	
09 AFLAS	
11 V8588	
12 KALREZ 7075	

PINS	
I INCONEL (Optional)	

Butt weld connections MUST specify a schedule.  
All API connections are "RTJ" style by default.  
API flange bore (SCHEDULE) is specified by API.

**Taylor Valve Technology**  
8300 S.W. 8th Street  
Oklahoma City, Oklahoma 73128

**TEL** 405.787.0145  
**FAX** 800.805.3401  
**WEB** www.taylorvalve.com  
**EMAIL** info@taylorvalve.com

\*See back page of actual choke product brochure for a more detailed order number example.  
\*For more options, contact Taylor Valve.

REVISED: 06-10-21

